

# RAYCON BULK

## Product Sorting System for bulk materials

- ✓ **Precision inline detection and separation of metallic and non-metallic contaminants**
- ✓ **Compact, light-weight, modular design, easy to clean and maintain**
- ✓ **Multiple language capability and excellent ease of operation**
- Complete system with integral vibratory feeder and separation unit
- Low material losses using segmented separation system
- High throughput rate
- IFS and HACCP conformity
- State of the art solution to remove dense foreign bodies from bulk material
- Total system solution ready to connect



# RAYCON BULK

## Performance features



RAYCON BULK product sorting systems detect all contaminants that due to their density, chemical composition, or mechanical dimensions absorb X-radiation to greater degree than the surrounding product, for example, metal, glass, ceramics, and stone contaminants in food. RAYCON BULK will also detect some plastics (e.g. PVC, rubber).

The heart of the RAYCON BULK control is a high performance industrial PC incorporating a real-time operating system and sophisticated image processing software featuring user administration, multi-product memory, etc.

Operator input and set up is via a 10" LCD touch screen monitor (IP65).

RAYCON BULK product sorting systems incorporate the following:

- High performance long-life X-ray tube with integrated high voltage power supply
- High resolution detection unit
- Compact system design and low centre of gravity requiring minimum footprint
- Excellent radiation protection in accordance with all statutory X-ray regulations (<1 mSv/a)
- Easy to clean and maintain
- Flexible rejection and product handling options

## Function

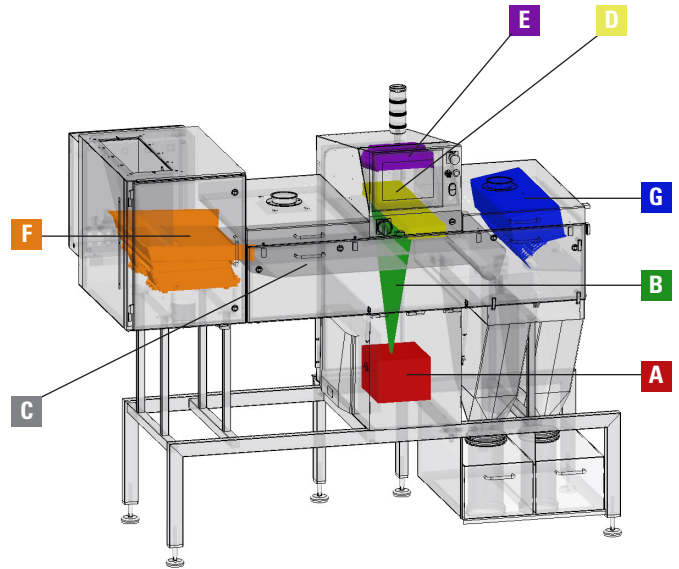

**The system comprises the following main components:**

### **A X-ray tube**

X-rays, emitted from the tube, are collimated through a narrow slot, entering the product as a fan shaped beam from bottom to top. Product height and density determines the amount of radiation absorbed.

### **B X-ray beam**

### **C Transport system**

A fixed speed conveyor belt transports product through the collimated, line X-ray beam. Scanning takes place line by line.

### **D Detector unit**

The linear detector row installed above the conveyor belt converts the incident X-radiation into an electrical signal, from which a digital X-ray image can be created and processed.

### **E Industry PC**

Images are processed and compared with the "standard" product and "rejected" or "accepted".

### **F Vibratory Feeder**

Bulk material will be uniformly and continuously distributed over the conveyor belt by the vibratory feeder.

### **G Separation system**

Detected foreign bodies are precisely removed by a segmented separation system with minimal product losses.

# Software advantages

## Processing software

X-ray images are evaluated by product specific image processing software contaminants detected and separated.

The RAYCON BULK sorting system's innovative software offers many advantages:

The real-time operating system with flash card ensures

- Exact timing of individual foreign bodies even at high throughput rates
- Safe data storage independent of external influences
- Full processor performance is used only for product inspection.
- Control over all hardware components at each process stage
- No UPS is required for system protection.

Additional features and advantages:

- Ethernet connection for data transfer and remote maintenance
- USB port for saving images, product backup and software updates
- Multiple i/o capability for the connection of photo cells, reject and separation systems, etc. allowing flexible integration into the production line.

## Cleaning:

For easy hygiene operations the top cover can be folded away and fixed in the open position. All guard covers are equipped with safety switches which isolate the source when a cover is opened.

This allows an hygienic cleaning of the complete system.

### Important information:

X-radiation is classified as ionising radiation but it is not radioactive! In compliance with EU directive 1999/2/EC, Sesotec X-ray systems due to the minimum radiation energy can be used for the contaminant inspection of food materials and with organic products.

The RAYCON product inspection system is subject to statutory X-ray regulations and requires certification.

It is important to observe any country specific regulations!

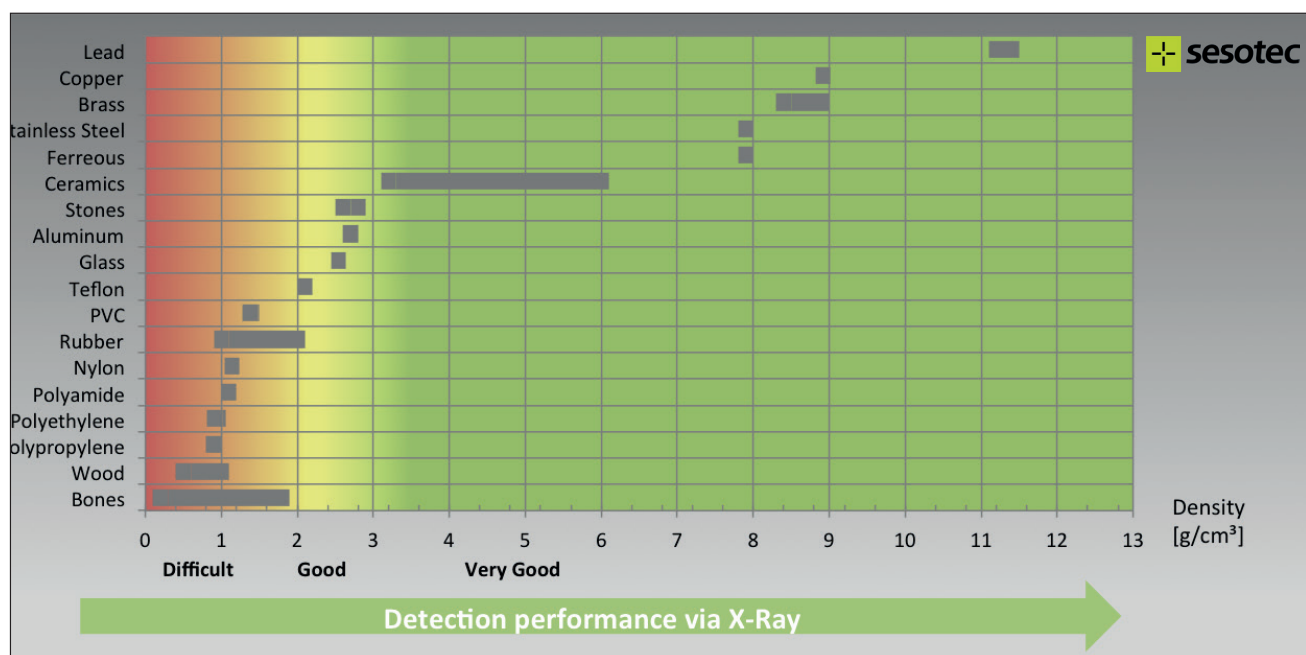

Detection capability for different materials categorized by density.

For more specific information please request our detailed technical data sheet.

## Sesotec GmbH

Regener Straße 130  
D-94513 Schönberg  
Germany  
Tel. +49 8554 308-0  
Fax +49 8554 2606  
info@sesotec.com  
www.sesotec.com

## Sesotec system world



### Detecting and separating contaminants:

Removing contaminants:

- metals
- plastics
- glass
- ceramics, porcelain, stones
- and many others

Removing from (good material):

- bulk materials
- liquids and pastes
- individually packaged product
- packed and loose items

Product types:

- end-products (food, textiles, plastics etc)
- industrial raw materials
- recycled materials

can be integrated into all types of conveyor systems



### Detecting and separating sub-standard products:

Qualitative defects:

- incorrect colour
- agglomerations
- breakages
- air inclusions in packs
- incorrect positioning / distribution

Quantitative defects:

- incorrect weight
- count errors (incorrect number of items in package)

Product types:

- end-products (food, textiles, plastics etc)
- industrial raw materials
- recycling materials

can be integrated into all types of conveyor systems



### Sorting mixed materials into single fractions:

Types of material:

- glass
- plastics
- metals
- and many others

Delivery flows:

- bulk materials
- individually packaged product

can be integrated into:

- conveying systems
- bulk material flows

## Operating Companies:



**Sesotec Ltd.**  
Hampshire  
United Kingdom  
Tel.: +44 1489 553 740  
info@sesotec.co.uk  
www.sesotec.co.uk



**Sesotec Sàrl**  
France  
Tel.: +33 388 04 2230  
info@sesotec.fr  
www.sesotec.fr



**Sesotec S.r.l.**  
Milano  
Italy  
Tel.: +39 02 7010 2377  
info@sesotec.it  
www.sesotec.it



**Sesotec Inc.**  
Bartlett  
USA  
Tel. +1 224-208-1900  
info@sesotec.us  
www.sesotec.us



**Sesotec Canada Ltd.**  
Cambridge  
Canada  
Tel.: +1 519-621-6536  
info@sesotec.us  
www.sesotec.ca



**Sesotec Pte. Ltd.**  
Singapore  
Tel.: +65 6562 8875  
info@sesotec.com.sg  
www.sesotec.com.sg



**Sesotec Pvt. Ltd.**  
Pune  
India  
Tel.: +91 20 2425 2147  
info.india@sesotec.com  
www.sesotec.com



**Sesotec Shanghai Co. Ltd.**  
Shanghai  
China  
Tel.: +86 21 37005075  
enquiry@sesotec.com.cn  
www.sesotec.com.cn



**Sesotec Representative Office**  
Üsküdar/Istanbul  
Turkey  
Tel: +90 216 504 18 72  
info@sesotec.com  
www.sesotec.com

... and more than 40 agencies worldwide

Made in Germany

For further information or to discuss your particular application contact one of our specialists.

[www.sesotec.com](http://www.sesotec.com)



Choose the Original  
Choose Success!